

Led high intensity type A - Compliant with high intensity type A
Flashhead

- 8 led projectors coming molded cable
- Aluminium and glass envelope
- No losing parts and no special tools required to remove projectors
- Led driver in stainless enclosure close to the flash-head, AC to DC converter with control in the power cabinet

Power supply

- 'Weather tight' stainless steel 316L power cabinet enclosure
- 8 independant power supplies providing a high redundancy level
- Test button for day, twilight and night
- Alarm dry contact NC and NO activated in case 1 or 2 led projectors not operating
- Surge protection included
- Master/slave configuration for multiple lights synchronisation or through external controller with optical cable

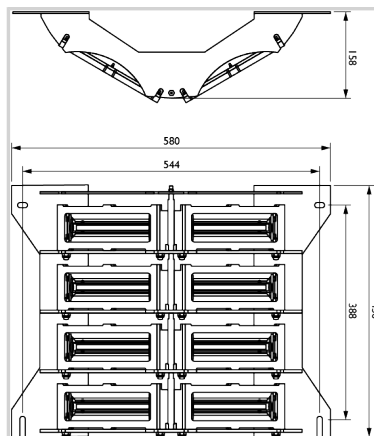

Electrical Characteristics	
Main voltage	110VAC to 240VAC +/-10% 50/60Hz
Average wattage	160W (day time)
Mechanical Characteristics	
IP degree	IP66 per projector
Wiring	Entry of cable by glands nickel plated brass and connection by terminals
Operating temperature	-40/+55°C
Weight	19kg for flashhead
Weight	19kg for flashhead
Wire cross section	from 1 to 4 mm ²
Photometric Characteristics	
Effective light output day time at 0° on site	200 000cd (white)
Effective light output twilight mode at 0° on site	20 000cd (white)
Effective light output night mode at 0° on site	2000cd (white)
Color day/twilight time	white
Color night time	White
Vertical beam spread	>3°
Horizontal beam spread	360° with 3 lights around the obstacle
Flash per minute	40
Standards	
Standards compliance	ICAO annexe 14 chapter 6 (8th edition 07/2018), EASA (4th edition 2017)

