

Low Intensity

OBSTA STIF

The **OBSTA STIF** is an obstruction light for hazard to low-flying aircraft (chimney, transmission lines, towers) designed for solar generator. The **OBSTA STIF** offers a power consumption much lower than conventional neon discharge lamp, which reduces size and cost of power supply, batteries and solar panels. The **OBSTA STIF** is cost effective and provides an ecological progress.

The **OBSTA STIF** based on cold neon discharge principle offers high reliability, robustness in hostile environments (EMC, climatic...) proven long life on all kinds of obstacle like transmission lines, TV towers and exposure in electromagnetic fields and high temperature.



Application

The OBSTA STIF is designed as a beacon for marking obstacles (chimney, towers, transmission lines, etc...). The OBSTA STIF falls into the low intensity type A and the OBSTA STIF B falls into the low intensity type B following ICAO definition, it complies also with L810 following FAA definitions.

The principle of cold neon discharge offers :

- inherent generation of the «aviation» red,
- a very long lifetime,
- excellent luminous intensity,
- very low power consumption,
- and compared to led light, a constant luminous intensity whatever are ambient temperature and EMC.

Description

The OBSTA STIF is a one piece moulded assembly, which includes a constant power converter and the discharge lamp and its special optic. OBSTA revolutionary new optic allows to reduce power consumption.

OBSTA STIF includes of :

- a clear glass envelope,
- a constant-power converter
- perfect watertightness,
- no requirement for a ground connection, which avoids any voltage return from the earth (for example due to lightning). The overall is thus considerably improved,
- a complete screening of the converter and the lamp to reduce electromagnetic interferences with antennas.

The OBSTA STIF also includes :

- protection against transient overvoltage,
- an alarm relay to trigger an alarm or light up an auxiliary lamp (if active redundancy circuits are used).
- in option, a fixing bracket ref. I3125.

The OBSTA STIF is easy to install and requires no servicing.

Main Characteristics

OBSTA part number	Power supply	Luminous intensity	Consumed current	Nominal power	Typical lifetime
STIF - I3410	12VDC	> 10 Cd	500 mA	6 W	> 100 000 h.
STIF B - I3330	24VDC	> 35 Cd	750 mA	18 W	> 100 000 h.

For others power, consult us

Complementary Characteristics

Light intensity diagram

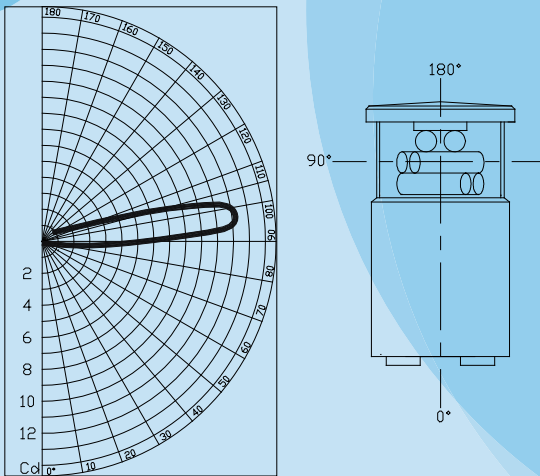

IP degree	66
Operating temperature	-30° + 60° C
Supply voltage	12VDC (-10 ; + 15 %) or 24VDC (-10 ; +15 %)
Weight	3,1 kg
Attachment	by 2 screws (tightening tickness 1 to 5 mm)
Wiring connection	on bare wires (2 power wires, 2 alarm)
Maintenance	without

Overall dimensions (in mm)

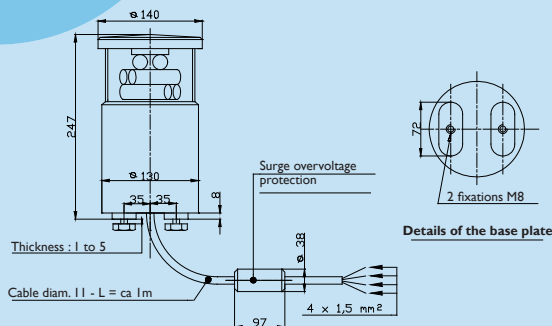

Specific precaution

For chimney installations, secure the lamp beneath the top (1,5 to 3m) in accordance with ICAO's Recommendations.

For installations with RFI risk, the power supply cable must be shielded

Complementary functions

- out of order alarm (relay switching)

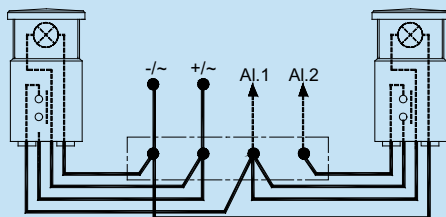

- automatic emergency lamp configuration enabling automatic control of an emergency lamp and/or an alarm in case of a fault with the main lamp (active redundancy),

- control by crepuscule photoelectric cell,

- CE compliance