

TECHNICAL DATA:

- Nominal voltage:
from 110 to 240 V rms - 50/60 Hz.
- Tolérances: min -10%, max +10%.
- Rated power: 50 W.
- Protection against transient waves
(impulses < 1 ms): built into the supply cable.
- Fault warning feature: yes (see electrical
wiring).
- Working température:
- 30° C to + 60° C.
- Warning contact maximum current: 5 Amps rms.

SETTING UP:

- When installed on a chimney, the OBSTA HISTI must be set below the aperture (from 1.5 meter to 3 meters) so that the smokes will not shadow on the light (ICAO annex 14, chapter 6).
- The ambient température must be lower than 60° C in order not to damage the electronics incorporated into the lamp.
- When installed near a high electro-magnetic field transmitter, the OBSTA HISTI operation may be disturbed.

ELECTRICAL WIRING:

- For installation with RFI risk, the power supply cable must be shielded.
- Wiring accessories are not supplied (boxes, entries, glands, ...).
- Do not cut the cable with the moulded protection off (see figure above).
- Install in the circuit an over current protection, with a 6 Amp. gl fuse, at easy reach.
- The electrical diagram is engraved on the body of the OBSTA HISTI.
- The lamp has no reference to the ground.
- An alarm relay is built into the lamp, allowing automatic switching of lights in case of failure, if twin lamps are installed (see drawing). The alarm switch can be used to supply the stand-by lamp and/or a remote alarm (buzzer, light, ...) with the above mentioned characteristics.

DIMENSIONS: (in mm)

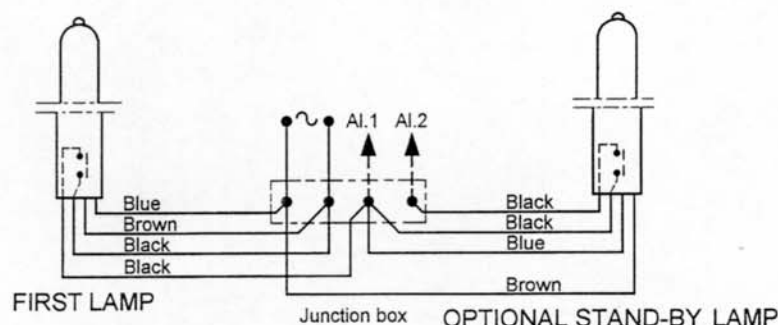
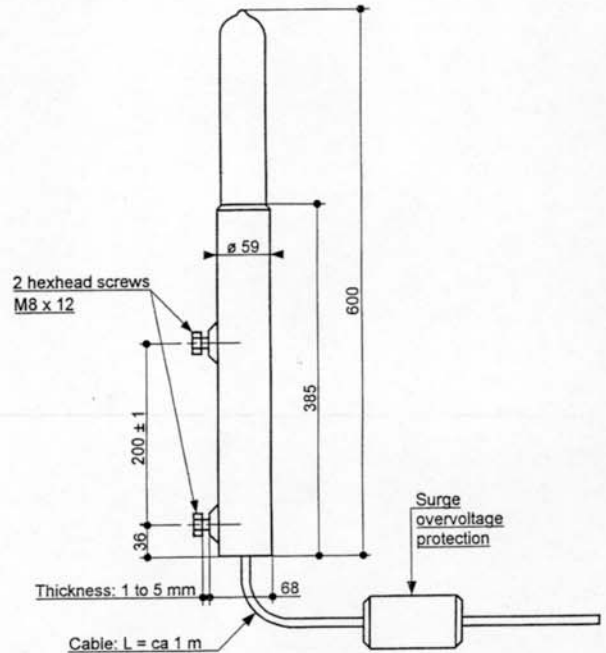

MOUNTING:

BY SCREWS:

1

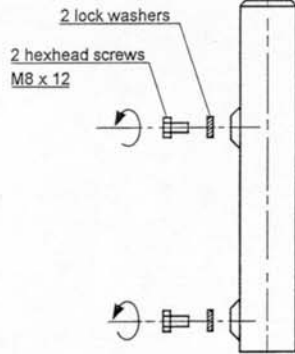

2

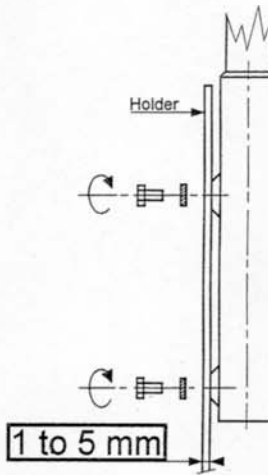

NOTE:
Don't change the 2
hexhead screws
M8 x 12

BY HARNESES:

1

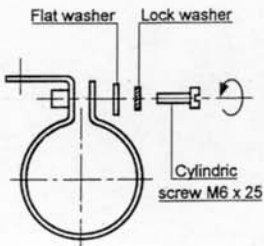

2

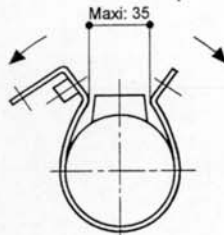

3

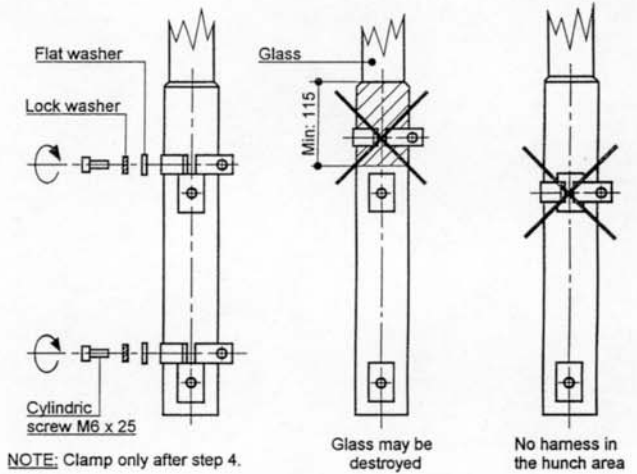

4

NOTE:
Washers and screws
for wall fixation are
not supplied.

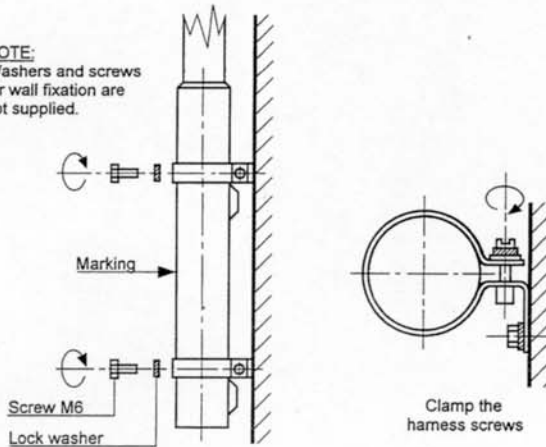

SUBSTITUTION:

WALL INSTALLATION:

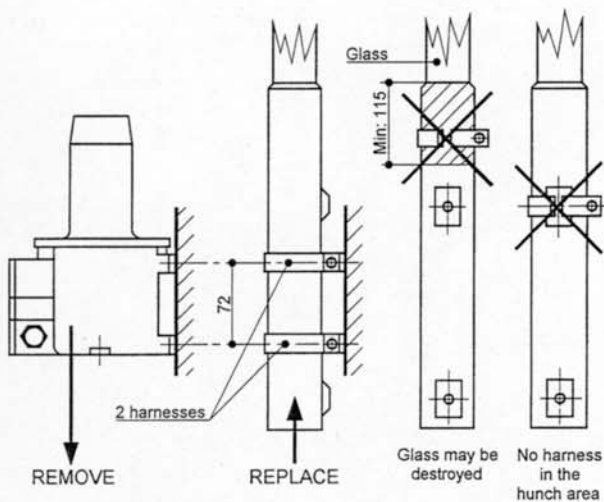

BOTTOM INSTALLATION:

NOTE: The corner plate is optional
(P/N # 13121).
Don't change the 2
hexhead screws M8 x 12.

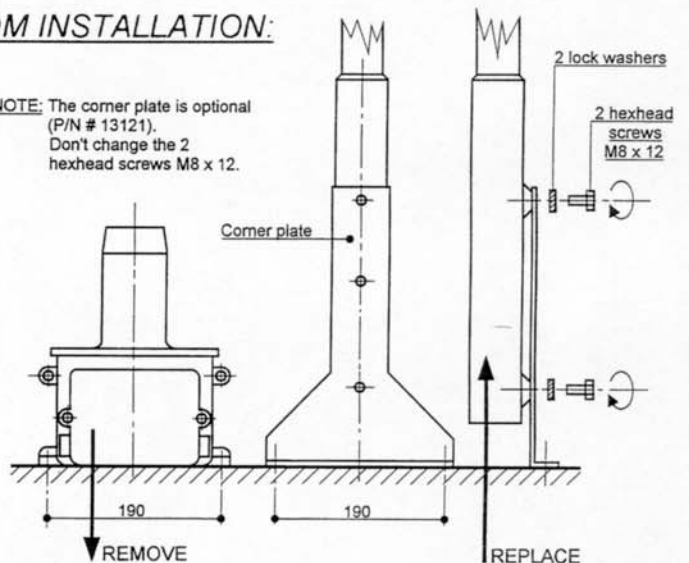

FIRST RUN:

CAUTION:

When switched on for the first time it is strictly recommended not to test the circuit with a high voltage generating tester lest electronic components be destroyed.

Before switching on, make sure that the line voltage is within the prescribed tolerances.

MAINTENANCE IN CASE OF FAILURE:

Quick trouble shooting synoptic.

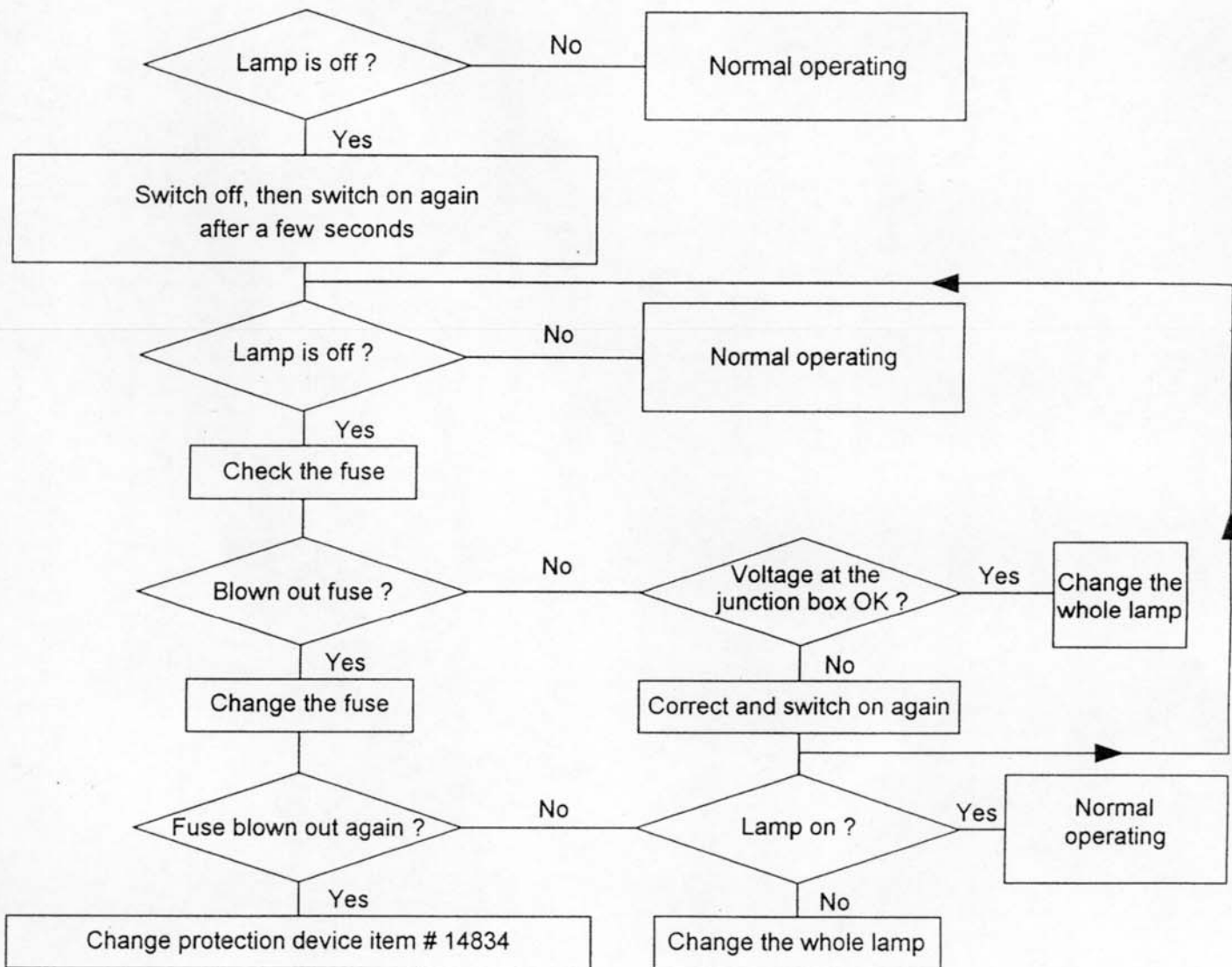

PROTECTION DEVICE REPLACEMENT:

The protection device against transient surge is directly connected and moulded to the cable. In normal operation, it will absorb the energy carried by the transients and self restore automatically, guarding for the next perturbances.

In case of a high power overvoltage surge, it will fail short in order to protect the lamp's electronics. For replacement, cut it off, and connect a new one. The junction must be well protected against weather.

Exact CLAUDE reference of this protection for OBSTA HISTI is item # 14834. It is advisable to cast the assembly in a special enclosure such as SCOTCHCAST 3M item # 92-A2F.

We have designed our packaging in order to assure that our product may be shipped and stored without undergoing any damage. ALL PRODUCTS NOT TRAVELLING IN THEIR ORIGINAL PACKAGING, INCLUDING PRODUCTS BEING RETURNED TO OUR FACTORY, FOR ANY REASON, ARE NOT COVERED, IN ANY CASE, BY THE MANUFACTURER'S WARRANTY.